

Multi-beams Active Infrared Sensor

User's Manual

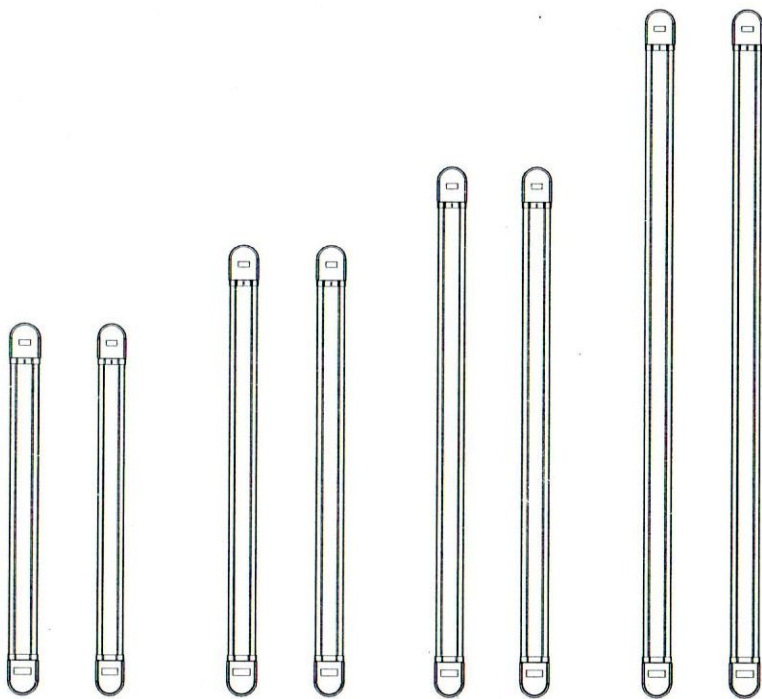

Outdoor 5m/10m/20m/40m/50m

X-beams number:2,3,4,6,8,10 beams

Thank you very much for choosing our product. Make sure that you have read this manual before use. It will make your use more efficient.

1. Summary

Indoor and outdoor dual-purpose multi-beam active infrared detector is a modern high-tech products, This product has a simple and convenient installation and debugging, Pleasing in appearance Etc., Apply to offices, schools, villas, factories, etc. need to guard against thieves entering the local, Play the role of the perimeter to guard against alarm. Can effectively guarantee your safety and to avoid damage to property.

2. Capability

- 1, intelligent judge: the use of multi-beam on radio and dual-beam identification principle, When the thieves access to protected areas, When the Two or more adjacent to the infrared beam has been blocked, the alarm signal will sent out. It has the advantages of intelligent judgment, and can effectively overcome traditional alarm detector false Alarm and Leakage alarm.
2. Identifying objects: May distinguish the traversing object the size, When has the illegal intruder invasion the Immediate alarm. And when there are cats, dogs, etc. through do No alarm .
3. High Reliability: In addition to tamper with, anti-shear line functions, the use of anti-interference technology, effectively prevent the intruders used a means of deception and destruction, with a good preventive effect.
4. Good compatibility: add Wireless modules, Alarm signal by wireless transmitting, can cooperate with other alarm system.
- 5, water-resistant moisture-proof: Have guard against rain structure ,All the fence is the best performance in waterproof ideal.
6. Beautiful structure: The outer covering main body uses the Double-shell structure, The outer layer is the high quality aluminum alloy, inner layer is PC engineering plastic Prevents the PCB and the aluminum alloy outer covering short circuit ,and raise the product's safety and the service life.
- 7, easy installation: the transmitter and receiver can be infinitely to achieve 360-degree rotation.

3. Name of Components

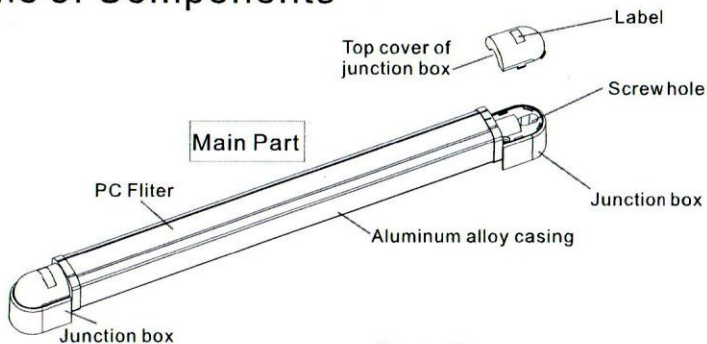

Barrier Detector Sensitivity Selection

A: How to adjust sensitivity Transmitter

- (1) H is for high power.
 - (2) L is for middle power.
 - (3) If you need a lowest power, please do not connected H and do not connected L;
 - (4) D1、 D2 is frequency selection.
- Factory setting is high power, It is for standard distance.

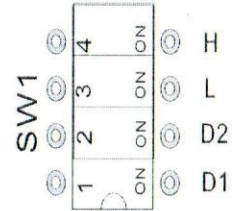

Receiver

- (1) SYN: synch
OFF is synch; ON is not synch.
- (2) SPB: Buzzer
OFF is sound to close; ON is sound to open
- (3) D1、 D2 is frequency selection

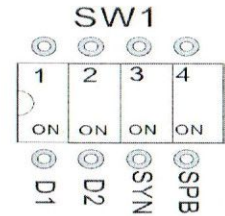

B: Frequency selection

- frequency1: D1、 D2 selection OFF.
 frequency2: D1 is selection ON, D2 is selection OFF.
 frequency3: D1 is selection off, D2 is selection ON.
 frequency4: D1、 D2 are selection ON.

3. Working Mode Selection

When SW1 into "OFF" position sensor work in synchronous mode, in "ON" position sensor work in asynchronous mode

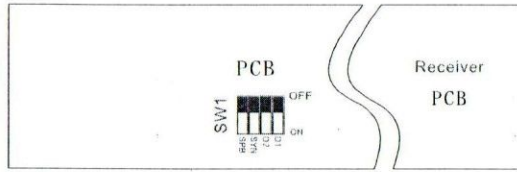

5. Connection methods

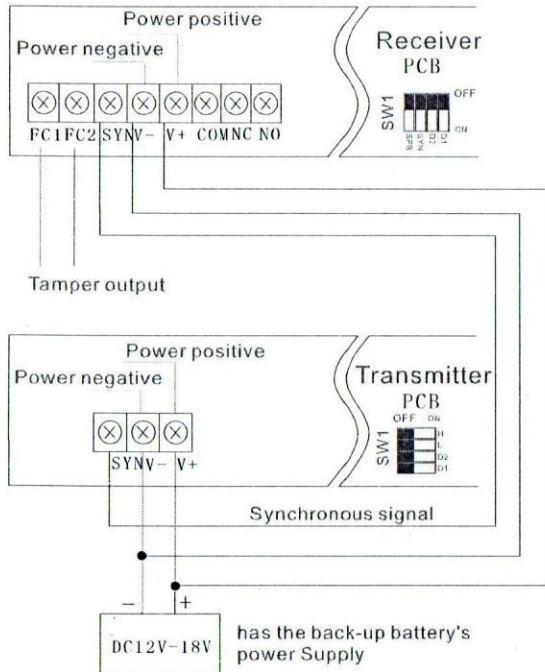

Notice

When install it outdoors, please conduct following the sketch map in case of water enters the detector through the cable and cause serious problems, such as false alarms, short circuits, electrocircuit board rustiness, etc.

4. Sensors installed on the need to guard against the location,

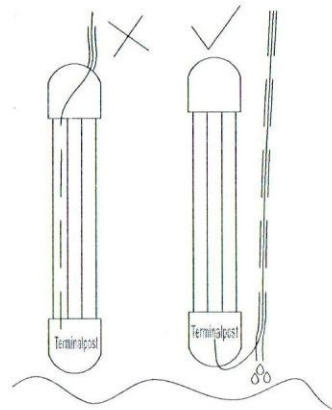
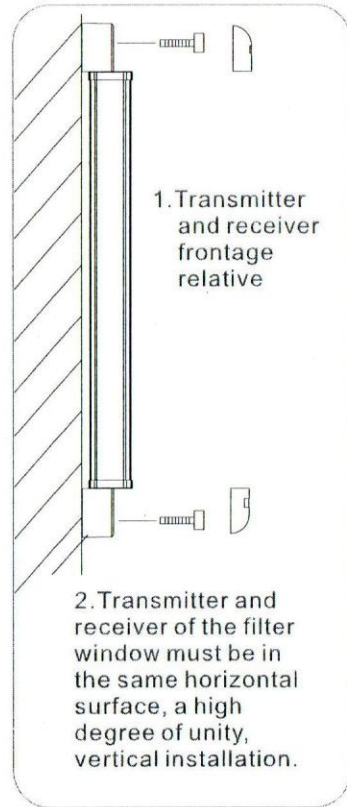

6. Dig the installation holes on the wall with Drill $\phi 6$, drive in the plastic pole and mount the bolt sleeve; then fasten mounting brackets with M3*40 grub bolt.

7. Confirm the transmitter and receiver are mutually corresponding, When switching power supply, The transmitter power instruction green light is bright, When mutual aiming, the receiver's red indicator black out.

8. screw up the fansten bolts on projector and receiver mounting brackets, then close up the top cover of brackets.

9. The receiving railing will send out wired /wireless signal in the case of any situations below:

- A. Tow or more adjoining infrared beams are cut off by an object.
- B. Power supply wire is artificially nipped.

6. Debug method

Optical axis adjustment method

1. set the receiver sw1 on "SPB" in "ON" location
2. Transmitter and receiver connected to the power supply.
3. Will transmitter and receiver respectively in horizontal direction of rotation, When buzzer sound Cleared is the alignment .
4. If has not been able to aim, the buzzer will make a sound, the receiver alarm red Indicator is bright

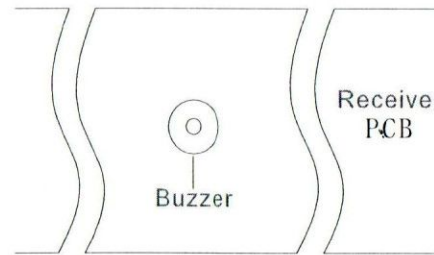

5. Alignment is completed, the receiver of SW1 on the "OFF" position.

7. Wireless module installment

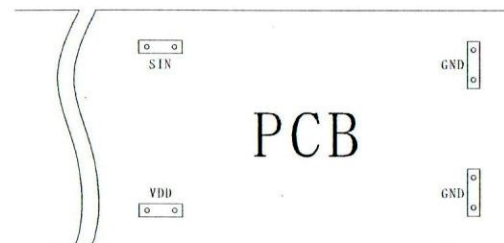

1. The wireless's module must match in addition, please press the graphical representation to carry on the installment .
2. Wireless module code should be matched with alarm controller, alarm controller can receive the alarming signal from the sensor.

8. Action Confirmation

After setting, please be sure to conduct walking test and action confirmation according to the following table.

Name	State	Indicator
Transmitter	power on	green LED on
Receiver	Protecting	Green LED on, Red LED off
	Alarming	red LED on

9. Technical parameters

Model	5x/10x/20x/40x/50x						
The number of beams	2 beam	3 beam	4 beam	6 beam	8 beam	10 beam	
Height	408mm	528mm	708mm	1050mm	1350mm	1670mm	
Working voltage	DC10.5~18V						
Current	Transmitter	15±3mA	20±3mA	22±3mA	40±3mA	47±3mA	58±3mA
	Receiver	40±3mA	42±3mA	44±3mA	46±3mA	48±3mA	50±3mA
Response time	≤0.1sec						
Relay contact capacity	1C, 30V AC/DC, 0.5Amax						
Environment	-25°C ~ +55°C, RH≤95%						
Distance	5~40m						
Alarm output	Wired, wireless						
Relay action time	Open time ≥ 1.5s						
Adjustable angle	Horizontal 180° (±90°)						
Material	PC plastic and aluminum alloy						

10. Troubleshooting

Fault performance	Fault causes	Countermeasure
Transmitter or receiver indicator does not light	Abnormal power supply voltage (short circuit or open circuit)	Check the power supply wiring
When the beam was blocked, the receiver alarm indicator light does not shine	Because reflection or other transmitter light enters the receiver	Remove reflection objects or change the optical axis
When the receiver was shading, the alarm indicator light, but not alarm	Signal line short-circuit or open circuit	Check wiring
	Bad contact	Check contact
False alarm	Supply voltage fluctuation	Check for voltage, ligand regulated power supply
	Installation base instability	Choose the firm foundation position reinstall it
	Optical axis is not fully aligned	Re-adjust the optical axis to the optimum position

4. Precautions for Installation

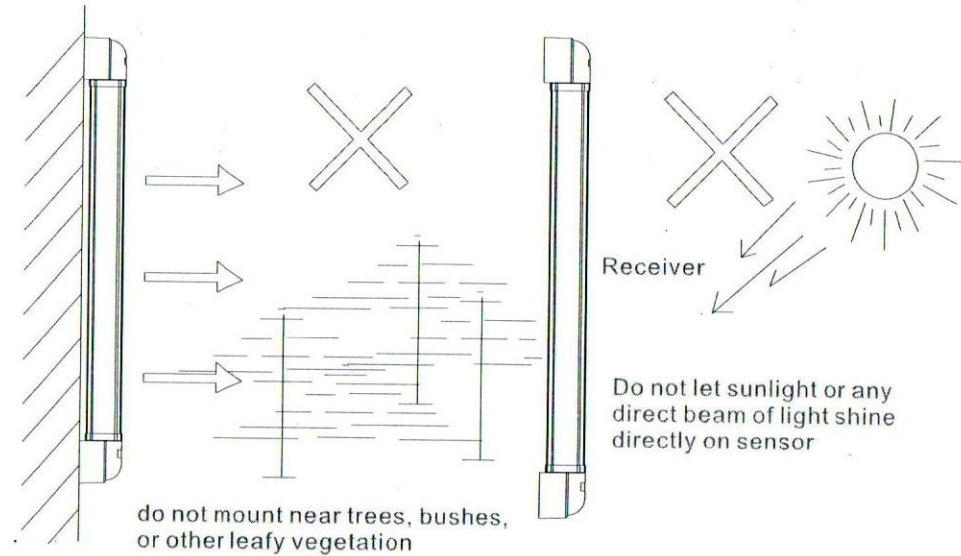

1. mounting brackets must be steadily installed to the wall in order to avoid becoming loosened or disengaged, which will cause wrong action.
2. It is not allowed any barrier between projector and receiver. (e.g. Tree)
3. avoid direct sunlight, lamplight or other strong light.
4. this product requires DC stabilivolt 10.5-18V power supply, the ideal choice is rechargeable accumulator backup battery. It is not allowed to use nolinear switch power supply.
5. Work in synchronous mode, the transmitter and receiver must be connected the power supply negative.

5. Installation method

1. Remove the cover

2. Passes through the wiring hole the electric cable to carry on the wiring

